

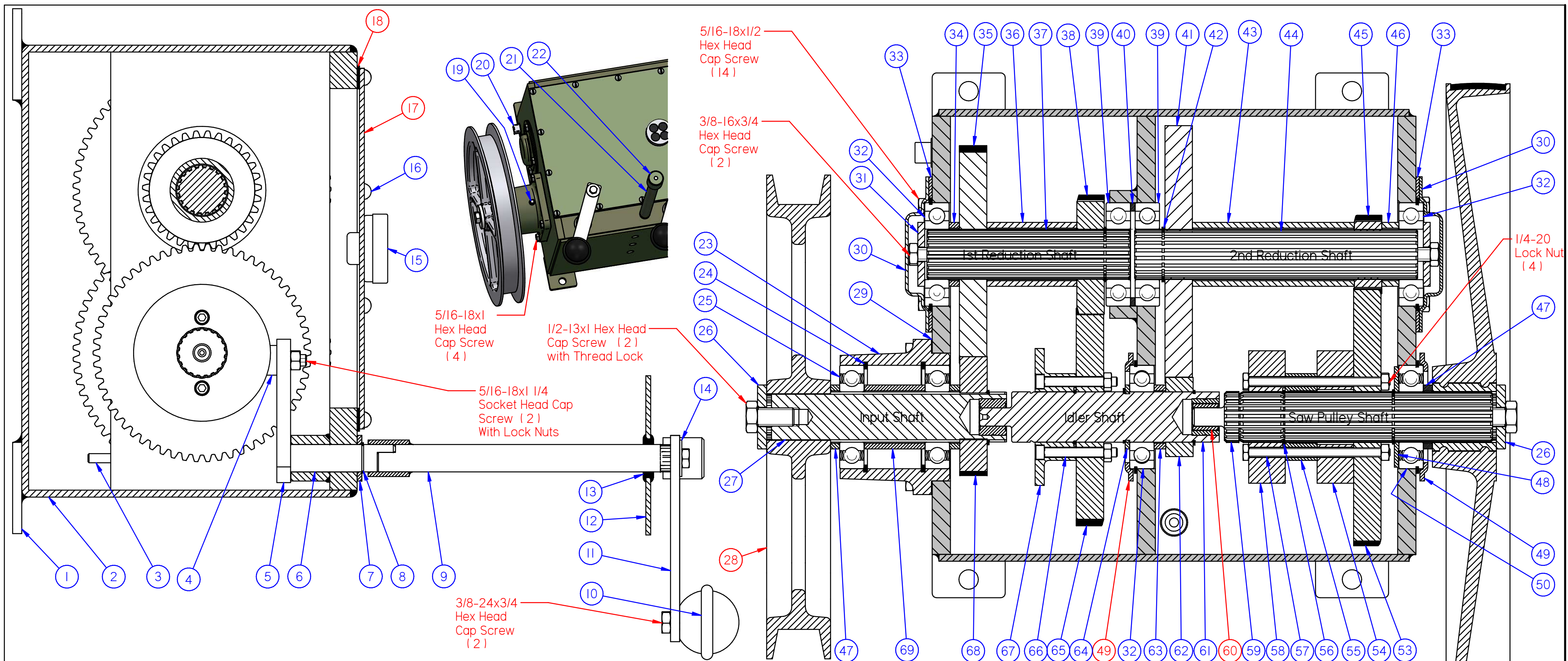

# GROB 4V-24 Parts

**GrobBandSaw.com**  
**888-550-3116**





Item Number	Part Number	Title	Qty.	Item Number	Part Number	Title	Qty.	Item Number	Part Number	Title	Qty.	Item Number	Part Number	Title	Qty.
1	18120-A	Pad	4	21	18329-A	Oil Filler Tube	1	41	18019-A	69T. Gear	1	61	18006-B	Idler Shaft	1
2	18033-D	4V Gear Box	1	22	18328-A	Filler Cap	1	42	5100-137	External Retaining Ring	6	62	18011-A	20T. Gear	1
3	18172-A	Trans. Dip Stick	1	23	18178-B	Housing	1	43	18021-A	4 7/16 Spacer	1	63	18012-A	.318 Spacer	1
4	18029-A	Inside Shift Knob	2	24	N5000-28I	Internal Retaining Ring	2	44	18018-B	Second Red. Shaft	1	64	18010-A	1/8 Spacer	1
5	18028-A	Inside Shift Lever	2	25	6207-2RS	Bearing	2	45	18020-A	20T. Gear	1	65	18007-A	58T. Shifting Gear	1
6	18068-A	Shifting Pivot Pin	2	26	18123-A	Clamp Washer	2	46	18076-A	Spacer	1	66	1/4-20 x 2	Socket Head Cap Screw	2
7	15243-A	Washer	2	27	18001-B	Input Shaft	1	47	18171-A	Lower Pulley Spacer	2	67	18071-A	Shift Ring / 58T. Gear	1
8	5100-75	External Retaining Ring	2	28	18055-C See NOTES	Drive Pulley	1	48	18325-A	Broached Bearing Spacer	1	68	18005-A	31T. Gear	1
9	18075-A	Shift Shaft Assy.	2	29	18088-A	Gasket	1	49	18026-A See NOTES	Bearing Clamp Plate	2	69	18003-A	Bearing Spacer	1
10	18385-A	M-80A Knob with 3/8-24 Tap	2	30	18022-A	Bearing Cover	2	50	6207-2RSNR	Bearing	1				
11	18061-A	Table Clamp & Shift Lever	2	31	15065-A	Clamp Washer	2	51	18105-I-B See NOTES	Lower Saw Pulley for 4V-18 Saws	1				
12	18175-5	Table Top	1	32	6207-NR	Bearing	3	52	GS-2079-A See NOTES	18" Rubber Tire	1				
13	G-1125	Rubber Grommet	2	33	18089-A	Gasket	2	53	18024-A	69T. Shifting Gear	1				
14	18124-A	Clamp Washer	2	34	18004-A	Spacer	2	54	18074-A	Shift Hub	1				
15	18373-A	Air Filter Assembly	1	35	18014-A	58T. Gear	1	55	18073-A	Shift Ring Spacer	1				
16	1/4-20 x 1/2	Slotted Rd Hd Screw	14	36	18015-A	Spacer	1	56	18179-A	Grob Shifting Ring	2				
17	18110-B See NOTES	Gear Box Cover, Steel Box	1	37	18013-B	First Reduction Shaft	1	57	18478-A	Hex Head Cap Screw	2				
18	18091-A See NOTES	Cover Gasket	1	38	18016-A	31T. Gear	1	58	18072-A	Shift Ring / 69T. Gear	1				
19	1/8-27 NPT	Pipe Plug	1	39	6207	Bearing	2	59	18023-B	Saw Pulley Shaft	1				
20	1/2-14 NPT	Pipe Plug	1	40	18017-A	1/8 Bearing Spacer	1	60	GR-8-N See NOTES	McGill Guidroll	2				

**NOTES**

Item 28 24001-C for 4V-24 and 4V-36 Band Saws  
 Item 60 AA-628-6 Oilite Bushing Used on Some Older Transmissions  
 New Style Cast Iron Box:  
 Item 17 18437-B Cover  
 Item 18 18438-A Gasket  
 Item 49 (Middle Plate) 18436-A Clamp

Item No. 51  
 Lower Saw Pulley  
 4V-18 18105-I  
 4V-24 24007  
 4V-36 24007

Item No. 52  
 Rubber Tires  
 18" GS-2079  
 24" S-1361  
 Glue: 3M 2141

Order By **PART NUMBERS ONLY**

<b>GROB INC.</b>	<b>GRAFTON, WIS.</b>
Transmission Assembly for Grob 4V Band Saws	

DRN. KS	TR.	CH. 4-11-07	DWG. NO.
DATE 7-18-03	SCALE	O.K. Rev 5	18180-C

NO. REQ'D	PATT. NO.	MATERIAL	HEAT TREATMENT
-----------	-----------	----------	----------------

Item Number	Document Number	Title	Quantity
1	#1652-B	Alemite Grease Fitting	1
2	18241-A	Vari-Drive Shaft	1
3	5100-125	External Retaining Ring	1
4	18242-A	Vari-Drive Retainer	1
5	18243-A	Vari-Drive Cup Shield	1
6	18252-A	Spring	2
7	18239-B	Vari-Drive Sheave, Front	1
8	18240-B	Vari-Drive Sheave, Rear	1
9	1/4-20 x 1/4	Set Screw-Cup pt. with Thread Lock	2

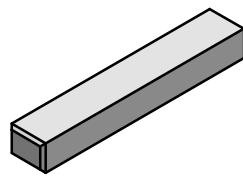
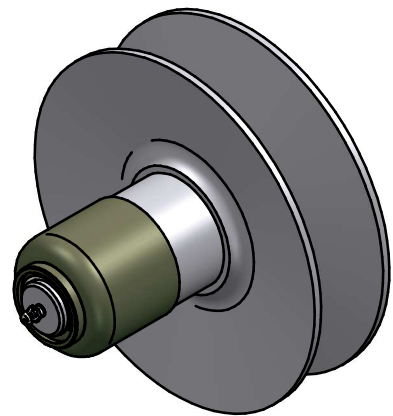
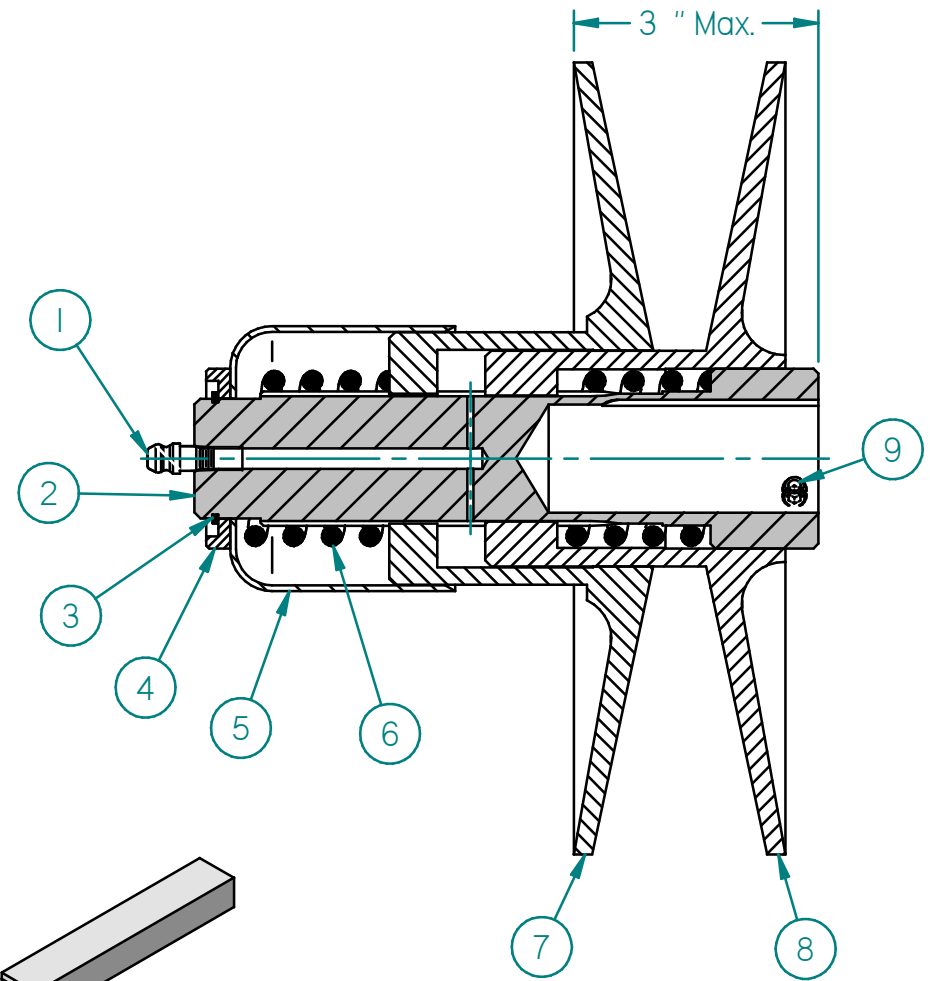

18351-A Key

First Used On	
Model	Serial No.
4V-18	1160
4V-24	638
4V-36	1061

<b>GROB INC.</b>		<b>GRAFTON, WIS.</b>	
Vari-Drive Pulley Assembly for 4V Band Saws			
DRN.	KS	TR.	CH.
DATE	1-29-01	SCALE	1:2
		O.K.	Rev 1
			DWG. NO. <b>18246-A</b>

NO. REQ'D	PATT. NO.	MATERIAL	HEAT TREATMENT

Item No.	Part No.	Description	Quantity
1	18219-C	Table	1
2	18165-A	Support Boss Sleeve	4
3	18164-A	Table Support Stud	4
4	18286-A	Table Support Stud Nut	8
5	18277-C	Table Trunnion Support	1
6	18108-A	Lower Guide Bar Clamp	2
7	18279-A	Table Trunnion	2
8	18278-A	Table Trunnion Clamp Channel	1
9	3/8 x 2 Pin	Slotted Spring Pin	2
10	18282-A	Table Tilt Clamp Block	1
11	5100-68	External Retaining Ring	1
12	5/8 x 1 1/4	Flat Washer	2
13	18283-A	Table Tilt Clamp	1
14	18281-A	Table Tilt Clamp Bracket	1
15	18348-A	3/4" Set Collar	1
16	18061-A	Table Clamp Lever	1
17	18385-A	M-80A Knob with 3/8-24 Tap	1

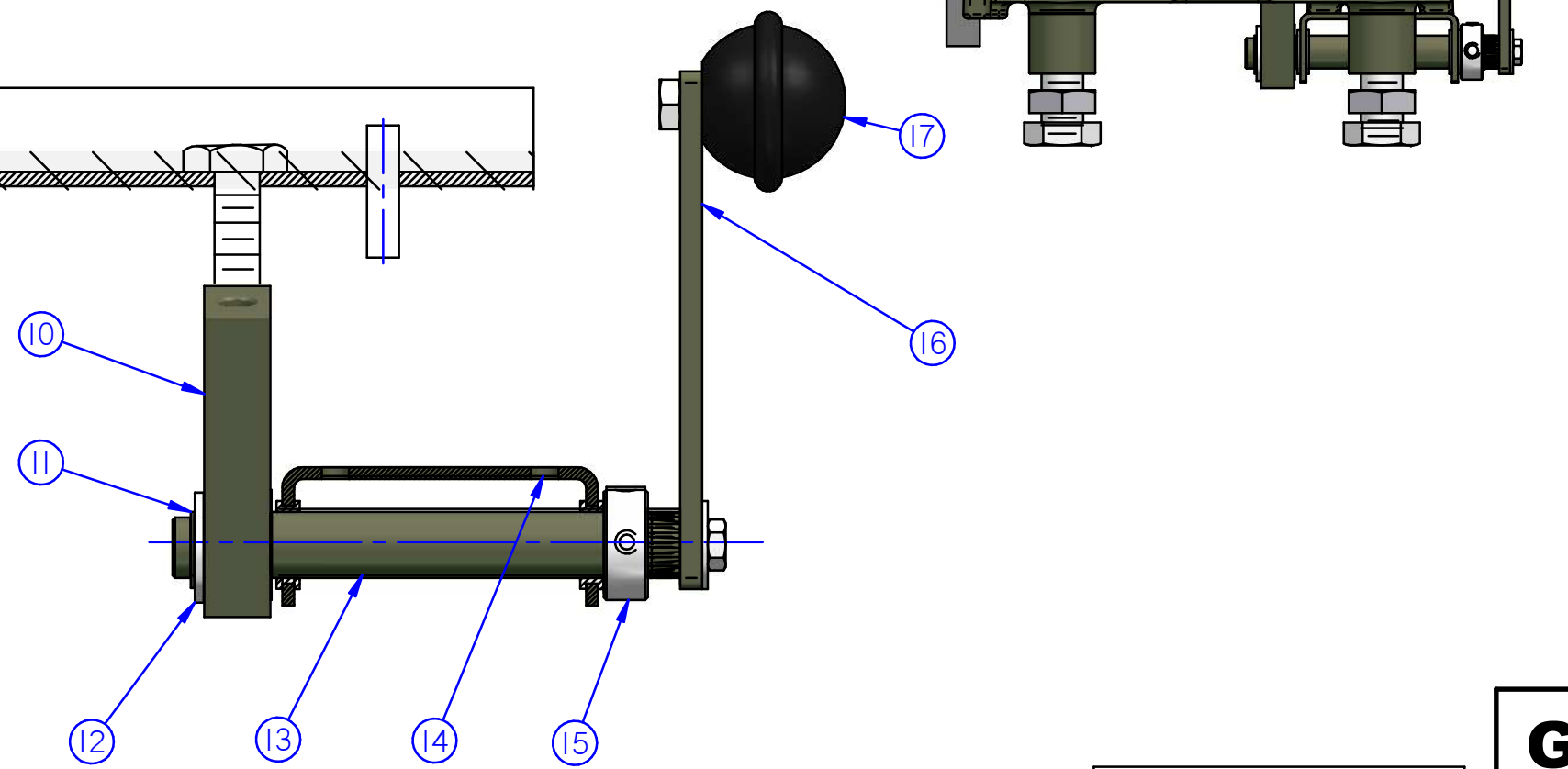
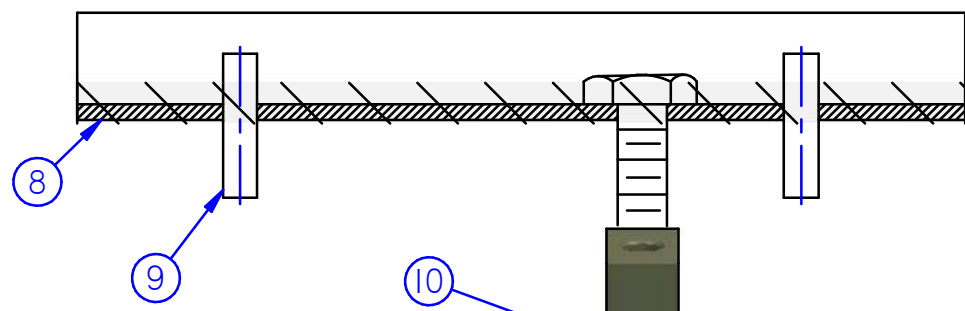
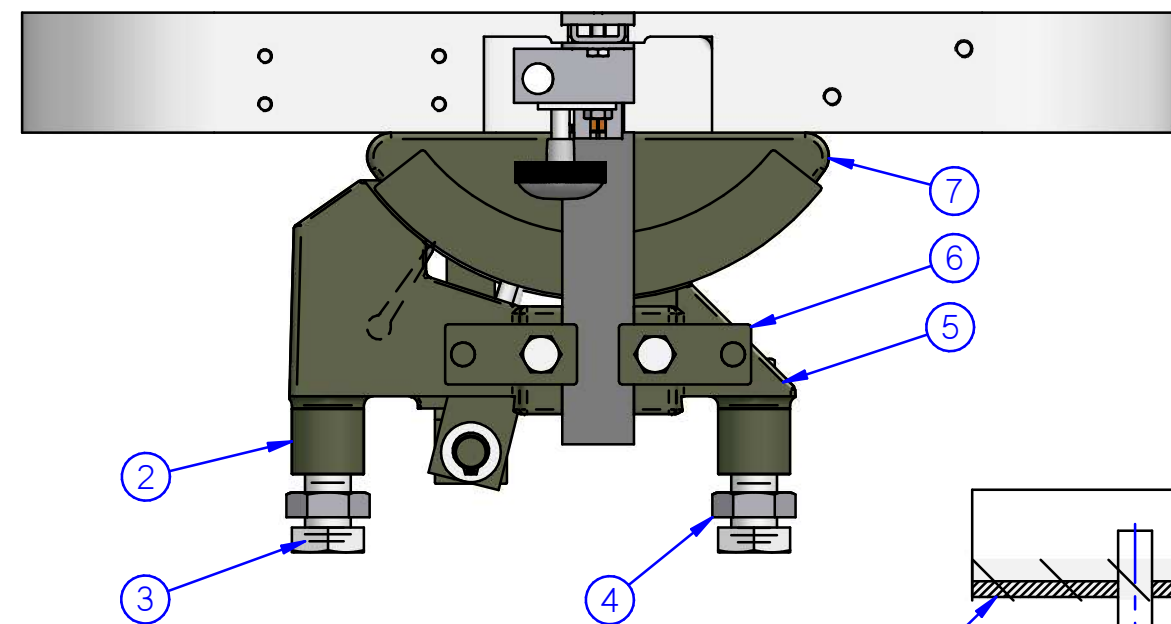
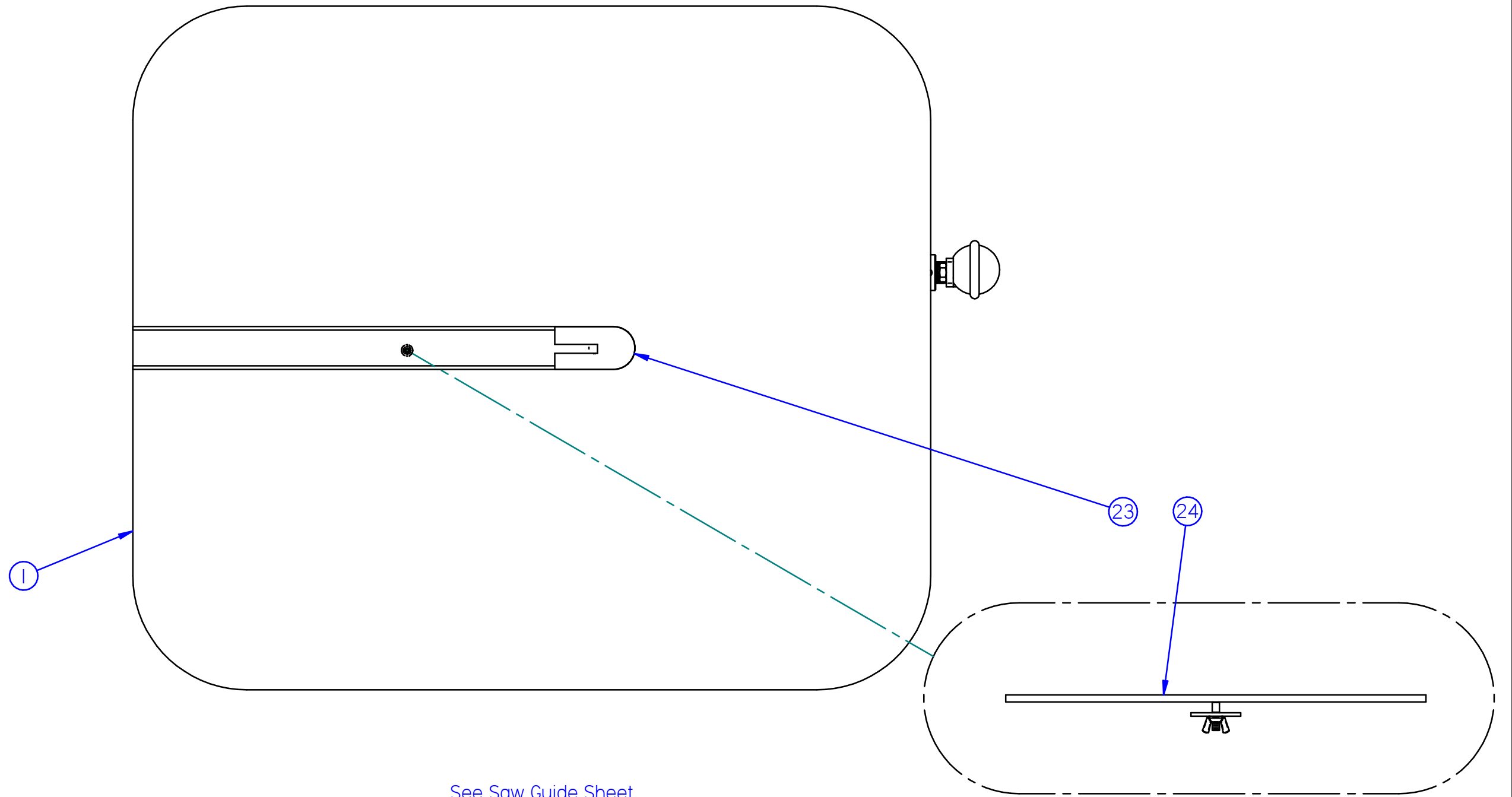

See Saw Guide Sheet for Optional Guides

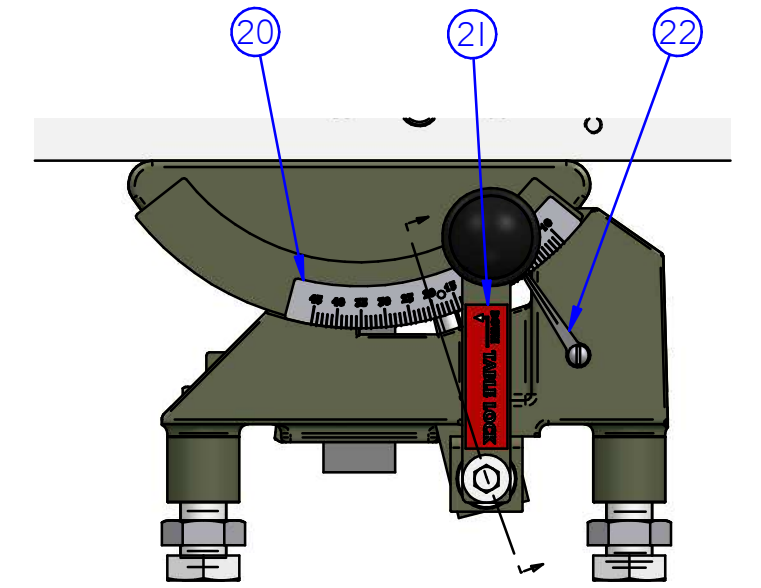

Item No.	Part No.	Description	Quantity
18	18100-A	Lower Guide Bar	1
19	18095-A	1/8-1/2 Lower Single Pc. Guide Holder	1
20	18053-A	Table Tilt Indicator	1
21	18212-A	Table Lock Decal	1
22	S-1163-A	Table Tilt Pointer	1
23	18146-A	Rear Table Filler Plate	1
24	18145-1-A	Standard Table Filler Plate Assembly	1

First Used on Serial Number			
4V-18	4V-24	4V-36	4V-60
2511, 2537-2542, 2550, 2556, to ...	1117-1118, 1174 to...	1267 to...	226 to...

Table Tilt: 45° Down Right  
5° Down Left

**GROB INC.**      **GRAFTON, WIS.**

Table Assembly  
for 4V Band Saws

DRN. KS	TR.	CH.	DWG. NO.
DATE 9-12-01	SCALE	O.K. Rev I	18284-C

NO. REQ'D	PATT. NO.	MATERIAL	HEAT TREATMENT

208/220/440/3Ph/60Cy

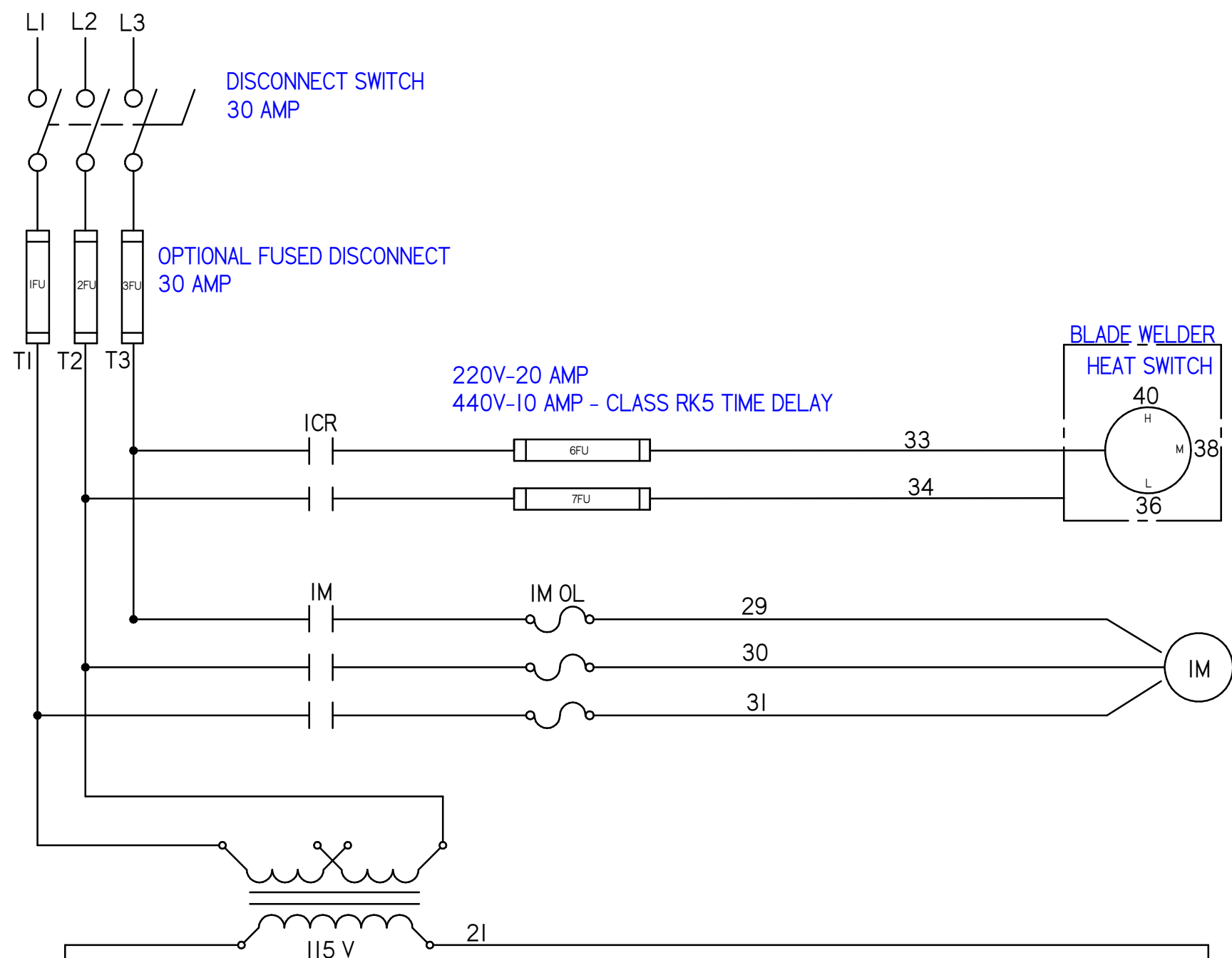

GROB RWA BLADE WELDER  
(OPTIONAL) RELAY & FUSES  
INCLUDED WITH WELDER

3 HP, 1750 RPM, 182T FRAME  
DOUBLE SHAFT

WELDER TRANSFORMER

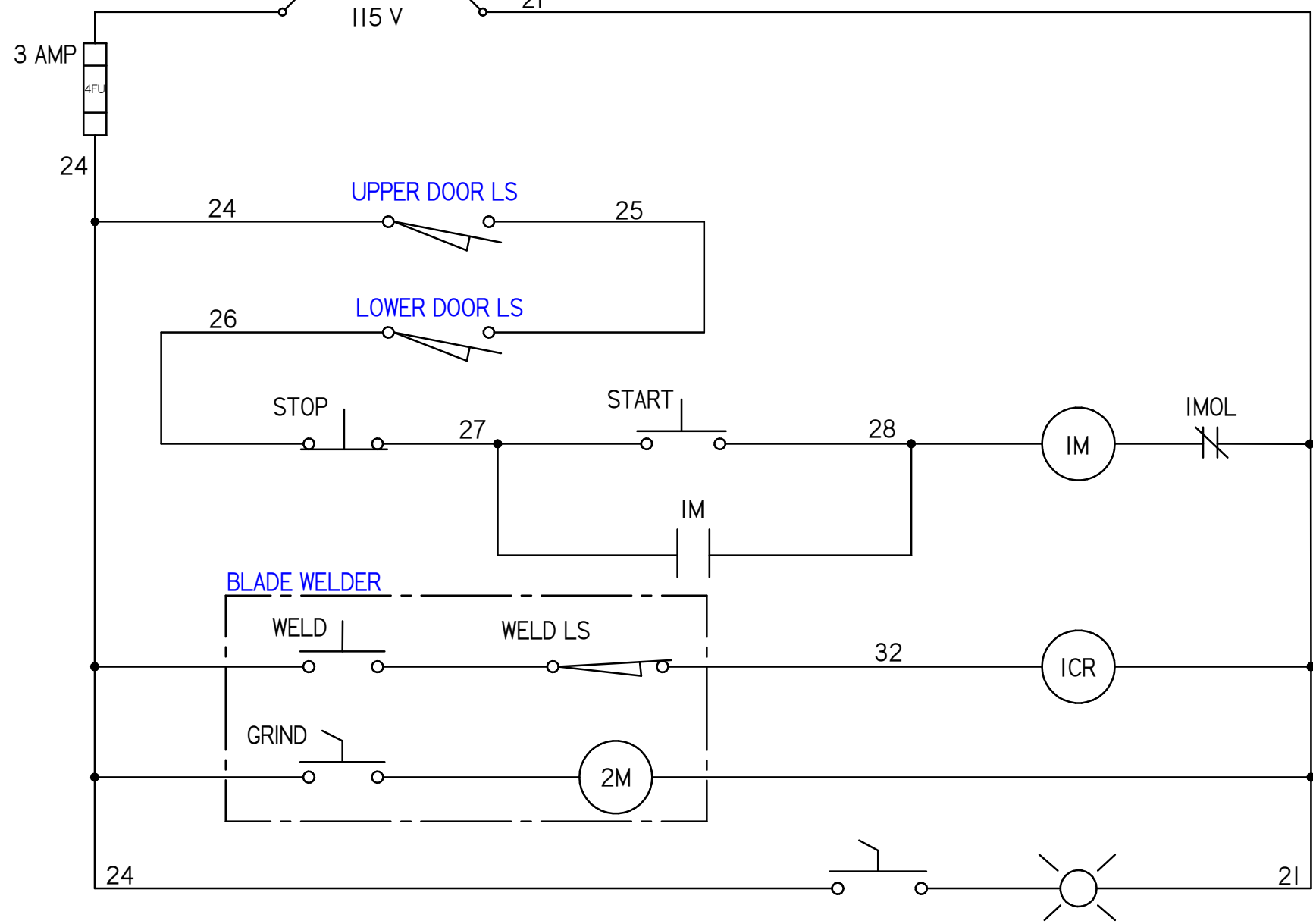
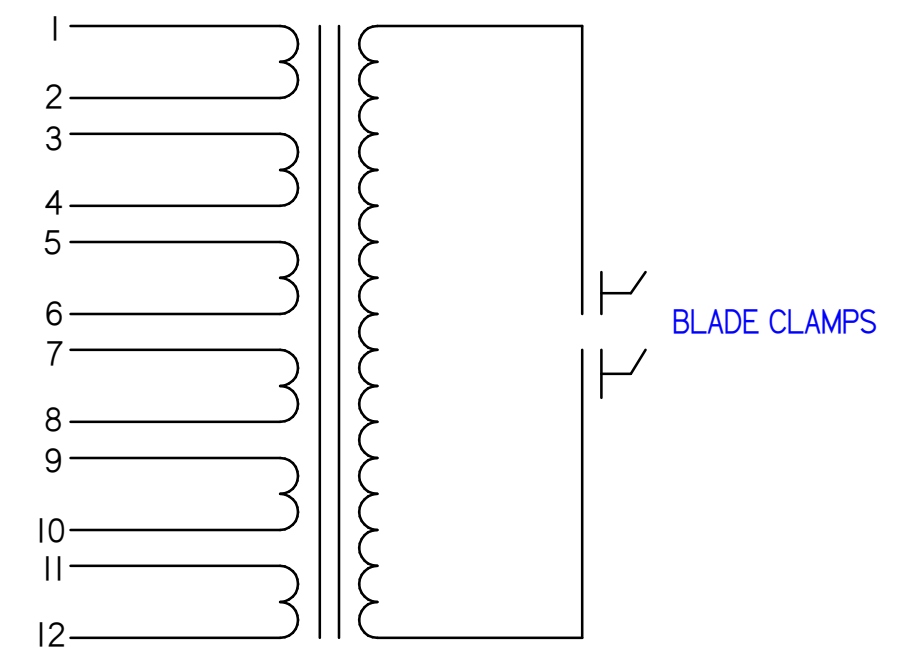

SAW MOTOR STARTER

BLADE WELDER RELAY  
(INCLUDED WITH WELDER ONLY)

GRINDER MOTOR  
(OPTIONAL ON BLADE WELDER)

WORKLIGHT  
(OPTIONAL)

WELDER TRANSFORMER TERMINAL CONNECTIONS

440 VOLT

32	32
33	33
34	1
35	2,3
36	4,5,36
37	6,7
38	8,9,38
39	10,11
40	12,40

220 VOLT

32	32
33	33
34	1,3
35	2,4
36	5,7,36
37	6,8
38	9,11,38
39	
40	10,12,40

JUMPERS

**GROB INC.**      **GRAFTON, WIS.**

SCHMATIC WIRING DIAGRAM    208/220/440 VOLT  
FOR 4V SERIES BAND SAW

DRN. SV	TR.	CH.	DWG. NO.
DATE 1-14-08	SCALE	O.K.	18410-C-1

NO. REQ'D	PATT. NO.	MATERIAL	HEAT TREATMENT
-----------	-----------	----------	----------------

Item No.	Part No.	Description	Qty.	Item No.	Part No.	Description	Qty.	Item No.	Part No.	Description	Qty.	Item No.	Part No.	Description	Qty.
1	18371-C	Electrical Assembly	1	14	15213-A	Blank Plate	1	27	18121-B	Motor Support Plate	1	40	18284-C	Table Assembly	1
2	182T	3hp 230/460v. Motor	1	15	24021-A	Speed Chart	1	28	18218-A	Motor Clamp Plate	2	41	18137-A	Rear Saw Band Guard	1
3	18246-A	Grob Vari-Drive Pulley	1	16	18128-A	Cover	1	29	18117-B	Motor Slide Channel	1	42	24011-C	Column Door	1
4	18122-A	Air Blower Support Plate	1	17	18390-A	Speed Adj. Handwheel	1	30	24007-1-C	Lower Saw Pulley	1	43	24023-D	Head Assembly	1
5	18127-A	Speed Indicator Pointer	1	18	24015-A	Speed Adjustment Screw	1	31	S-1361-A	24" Pulley Tire	2	44	24000-D	Frame	1
6	18111-B	Sawing Chart	1	19		3/4-10 Jam Nut	2	32	18295-A	Table Support Pin	2	45	18180-C	Transmission Assembly	1
7	18321-A	Push Button Plate	1	20	HS-398-A	Spacer	1	33	18372-A	Door Latch Assembly	2	46	24001-C	Drive Pulley	1
8	18323-A	Gasket	1	21	18210-A	Speed Adjustment Nut	1	34	24012-B	Base Door	1	47	18156-D	Concrete Base	1
9	Start Button	CH 10250T30B	1	22	18183-A	Spacer	1	35	18292-A	Lower Stabilizer Channel	1	48	24014-A	Rear Lower Base Cover	1
10	Stop Button	CH 10250T30R	1	23	S-1167-A	Washer	1	36	18260-B	Lower Saw Band Guard	1	49	24013-B	Rear Base Support Channel	1
11		Push Button Box	1	24	FF-620-5	Oilite Bushing	1	37	18267-A	Lower Guard Extension	1	50	18174-B	Leg for Frame	4
12	GS-2286-B	Blank Plate	1	25		5/16 Flat Washer	1	38	18293-A	Upper Stabilizer Channel	1	51	18189-A	Leg Cover	4
13	2322V681	4v-24 Vari-Speed Drive Belt	1	26		5/16-18 x 1/2 Hex Bolt	1	39	18291-A	Upper Table Support Brkt.	1	52	GS-2077-A	Lower Wheel Brush Ass'y.	1

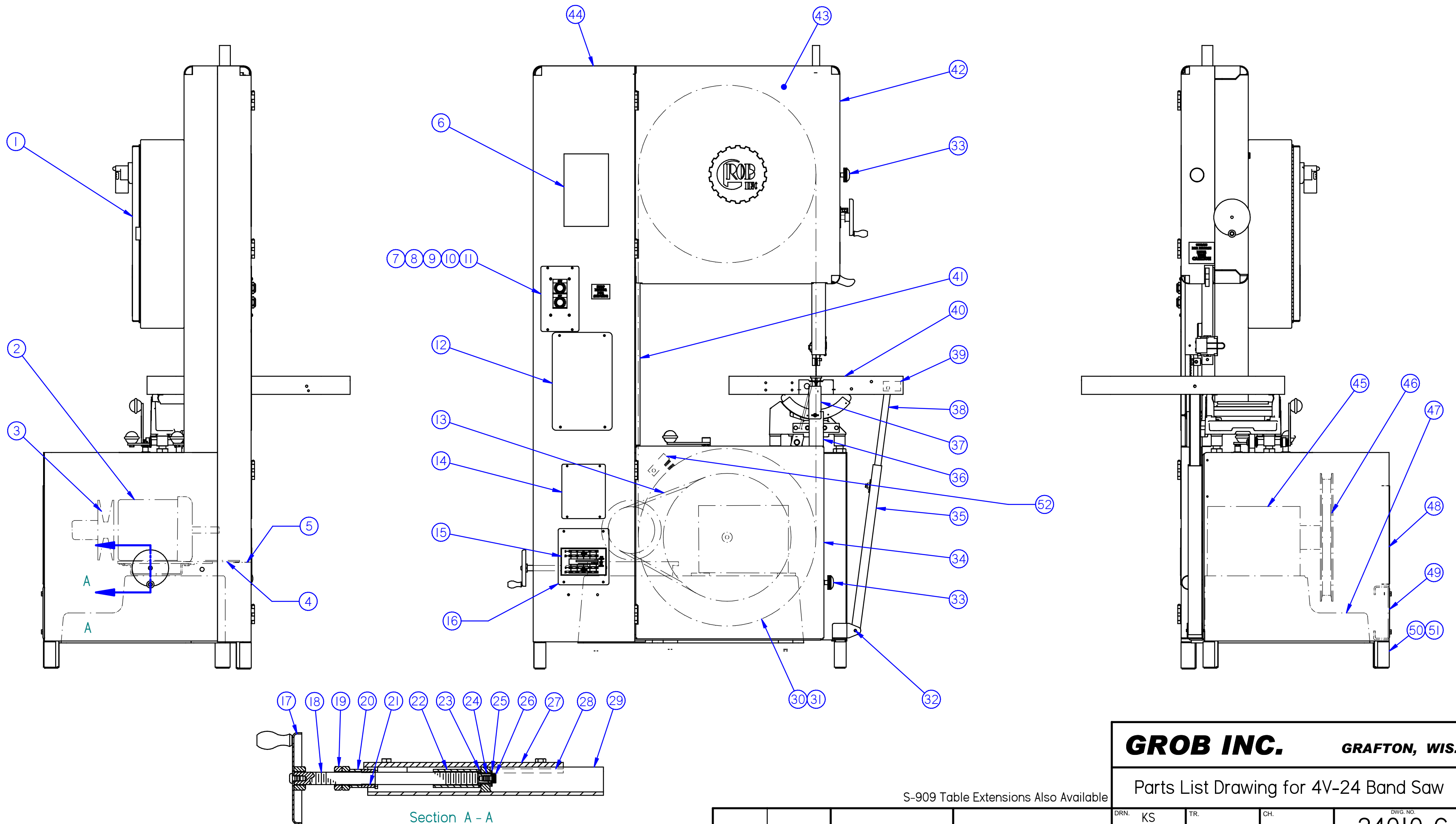

S-909 Table Extensions Also Available

<b>GROB INC.</b>		<b>GRAFTON, WIS.</b>	
Parts List Drawing for 4V-24 Band Saw			
DRN. KS	TR.	CH.	DWG. NO.
DATE 4-04-02	SCALE 1:10	O.K. Rev I	24010-C

NO. REQ'D	PATT. NO.	MATERIAL	HEAT TREATMENT

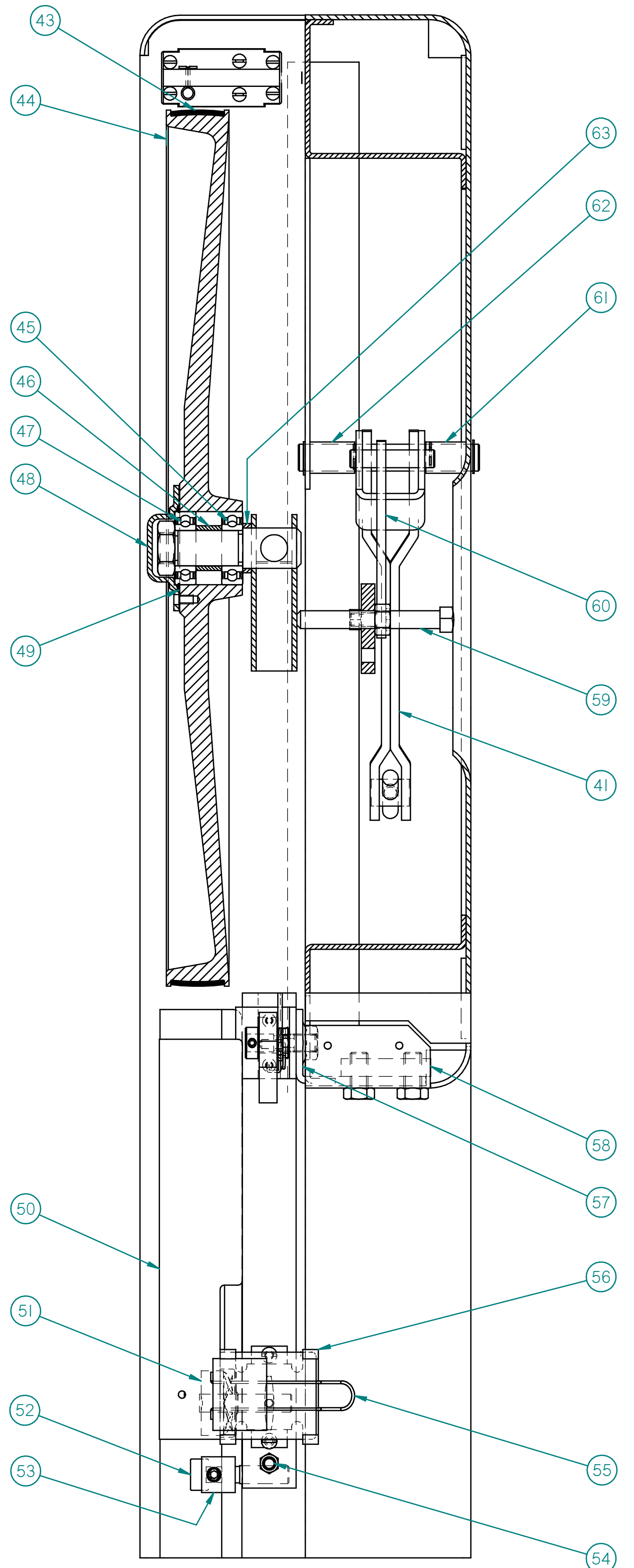
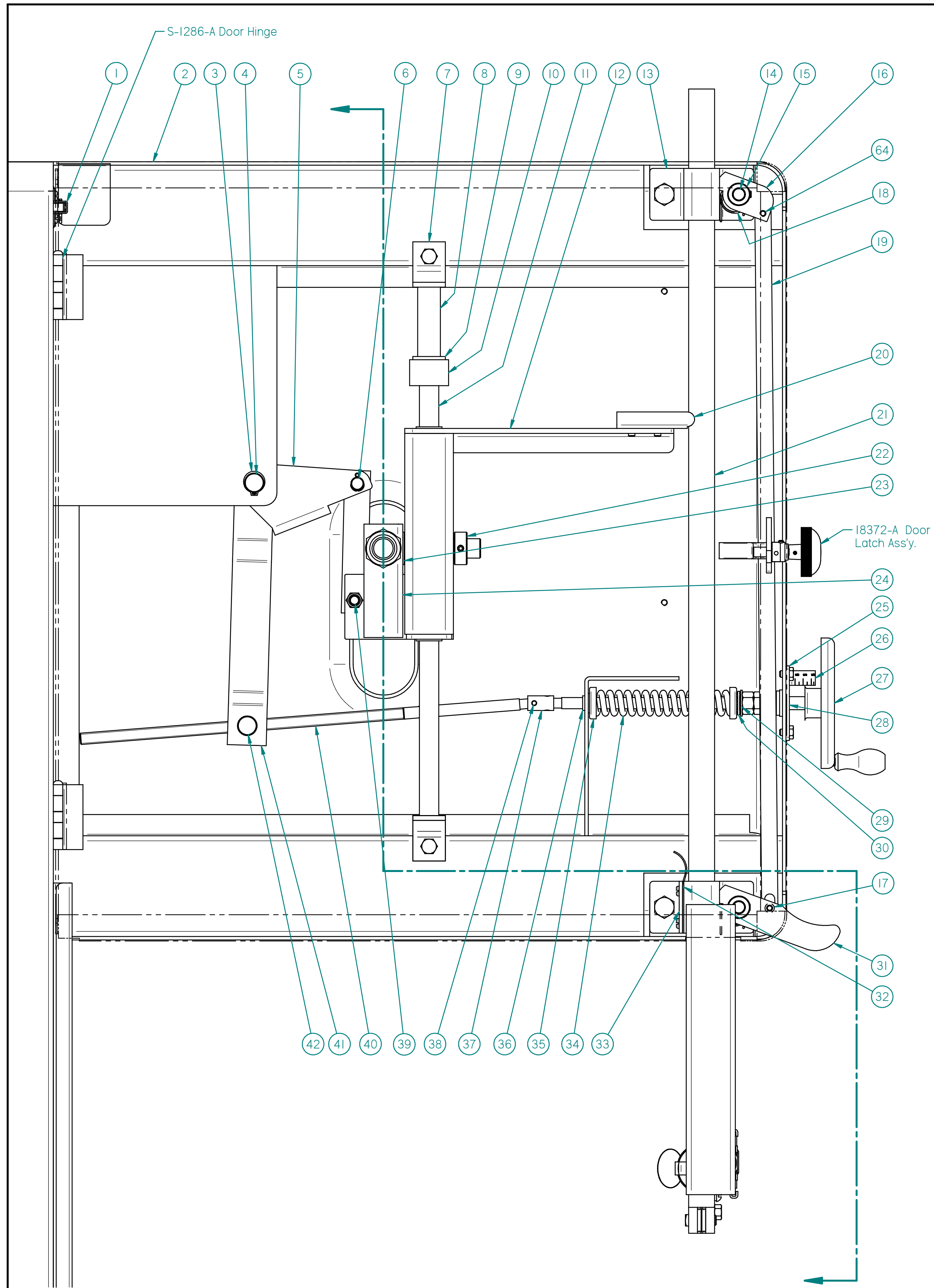

Item Number	Document Number	Title	Quantity	Item Number	Document Number	Title	Quantity
1	I8285-A	Door Limit Switch Assy.	2	33	I8289-A	Tension Spring Clamp Plate	1
2	24000-D	Frame Assembly	1	34	S-1135-A	Compression Spring	1
3	5100-75	External Retaining Ring	2	35	S-1084-A	Compression Spring Cup	2
4	24003-A	Tension Lever Pivot Pin	1	36	S-1102-A	Handwheel Shaft Bearing	1
5	I8158-B	Channel	1	37	S-1053-A	Coupling	1
6	I8173-A	Link Pin	1	38	I8358-A	Pin for S-1053	2
7	I8301-A	Tension Brkt Bar Clamp	3	39	I8163-A	Tension Bracket Link Pin	1
8	24008-A	Rubber Bumper Spacer	1	40	24018-A	Saw Band Tension Screw	1
9	I5243-A	Washer	1	41	24006-B	Tension Lever	1
10	S-1143-A	Rubber Bumper	1	42	S-1090-A	Tension Screw Nut	1
11	24002-A	Tension Bracket Bar	1	43	S-1361-A	Rubber Tire for 4V-24	1
12	24020-C	Tension Bracket Weldment	1	44	S-1353-I-C	Upper Saw Pulley	1
13	S-1017-A	Guide Bar Block	2	45	6205-2RS	Bearing	1
14	I8214-A	Guide Bar Clamp Pin	2	46	GS-2147-A	Bearing Spacer	1
15	I8232-A	1/2" Set Collar	2	47	6205-2RSNR	Bearing	1
16	S-1023-A	Guide Bar Upper Clamp	1	48	S-1152-A	Bearing Cover	1
17	GS-2222-A	Lower Clamp Link Spacer	1	49	GS-2367-A	Gasket	1
18	S-1077-A	Clamp Spring	2	50	I8141-C-12	Upper Saw Band Guard	1
19	24022-A	Guide Bar Clamp Link	1	51	S-1276-A	Saw Band Oiler Assembly	1
20	S-1096-A	Tension Bracket Slide	1	52	S-1151-A	3/8" - 1/2" Single Piece Saw Guide	1
21	24016-A	Upper Guide Bar	1	53	S-1071-A	1/8"-1/2" S-1124 5/8"-1"	1
22	I8348-A	3/4" Set Collar	1	54	S-547-A	Guide Holder Clamp Stud	1
23		Shim Washer	1	55	GS-2250-A	Guard Spring Clip	1
24	S-1296-B	Pulley Pivot Channel Assy.	1	56	GS-2249-B	Saw Band Guard Nest	1
25	I8177-B	Tension Screw Support Brkt.	1	57	I8169-A	Guide Bar Bracket	2
26	I8176-A	Saw Band Tension Indicator	1	58	I8185-A	Clamp Block	2
27	I8391-A	Tension Crank Handwheel	1	59	1/2-13 x 4"	Square Head Bolt	1
28	FF-707-5	Oilite Flanged Bushing	1	60	I8159-A	Tension Link	1
29	S-1167-A	Washer	1	61	24009-A	1 1/8" Spacer	1
30	R5498	NICE Bearing	1	62	I8161-A	1 1/4" Spacer	1
31	S-1022-A	Guide Bar Lower Clamp	1	63	I8324-A	Bearing Spacer	1
32	I8170-A	Guide Bar Tension Spring	1	64	GS-2222-I-A	Upper Clamp Link Spacer	1

Ref. 24010-C Parts List Drawing  
24011-C Column Door

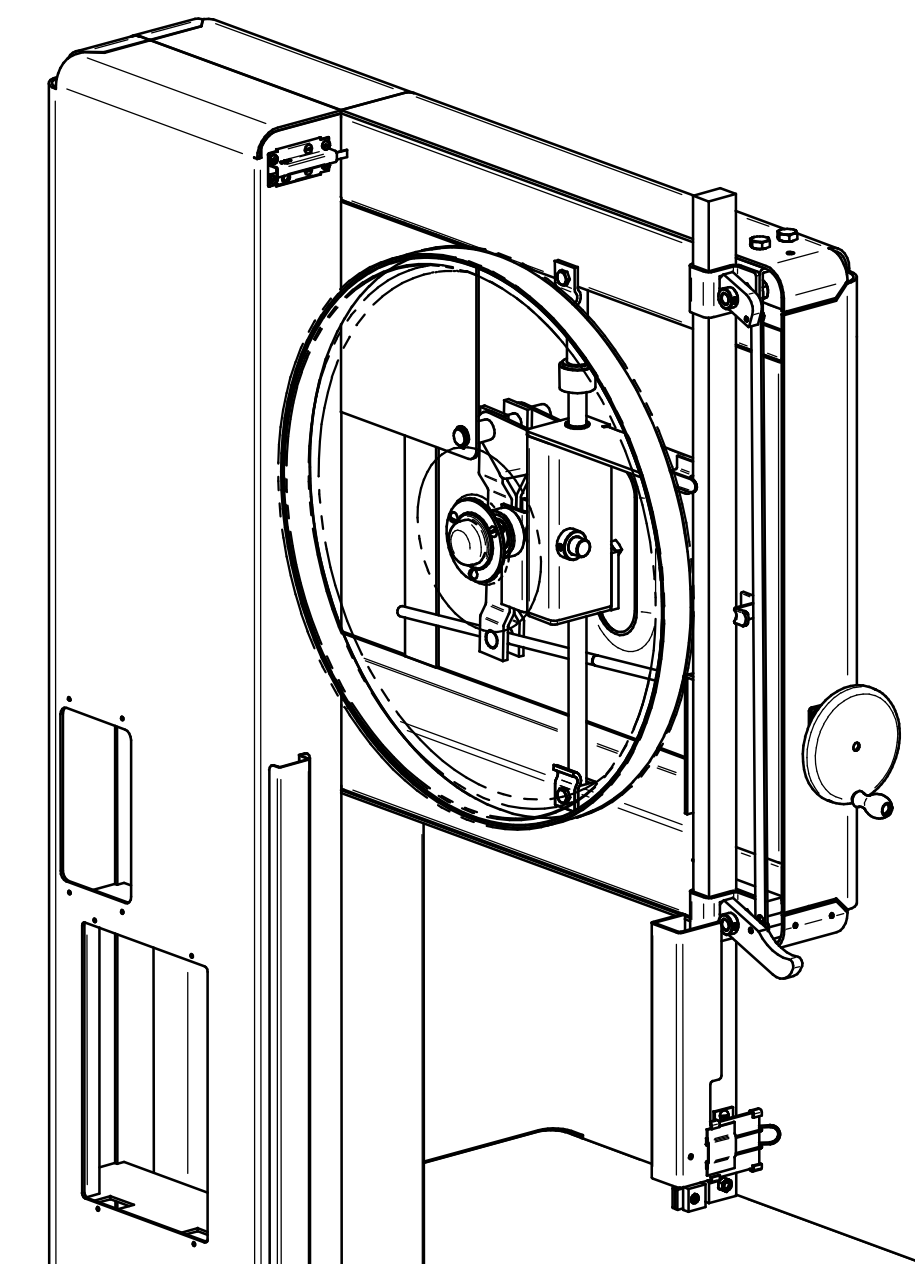

Item #52 Single Piece Hard Aluminum Bronze Saw Guide Shown. Carbide Also Available.  
See Guide Sheet for Other Listings.  
Item #53 Single Piece Guide Holder Shown. See Holder Sheet for Other Listings.

Redrawn 2-12-08 with Bearing Updates.

**GROB INC.** GRAFTON, WIS.  
Head Assembly  
for Grob 4V-24 Band Saw

DRN	KS	TR.	CH	Rev 2	DWG. NO.
DATE	10-24-01	SCALE	3/8	O.K.	24023-D

NO. REQ'D	PATT. NO.	MATERIAL	HEAT TREATMENT

# GROB INC.

## Installation and Maintenance

for

### Vari-Drive Motor Pulley #18246

#### Installation

Caution: Make sure Line Switch is on OFF.

- 1 Check motor shaft and key.
- 2 Before placing key on shaft, make sure pulley slides freely. Use a fine grade of emery cloth to remove any burrs or rust. Oil motor shaft for easy future removal of pulley. *DO NOT FORCE PULLEY ON SHAFT.*
- 3 Mount Pulley on motor shaft. Position its proper alignment to the driven pulley by using a straight edge bar or rule as shown below.

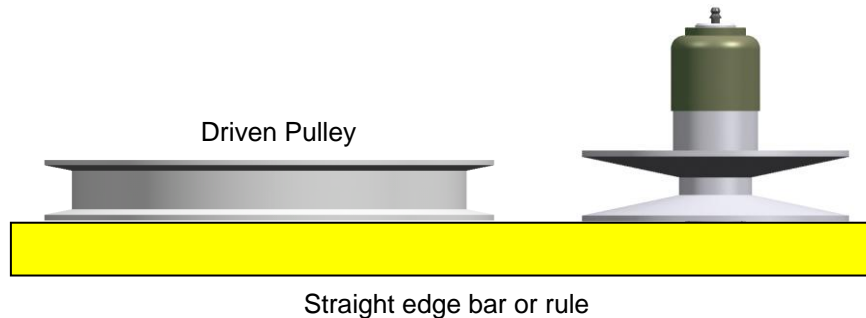

Note: *Alignment must be accurate to avoid undue belt vibration or wear*

- 4 When the alignment is correct, tighten the two self locking set screws.
- 5 REPLACING BELT: Turn speed crank to move motor towards gear box until it stops.
- 6 Use a wooden wedge to spread the sheaves apart far enough to permit belt to go on both pulleys. Remove wedge and rotate pulley until belt is tight. *DO NOT PRY THE BELT ON.*
- 7 The belt should run level between the faces of the sheaves. If one side rides high with belt on an angle, investigate immediately. Belt alignment may be the cause, or a defective belt.

(over)



# MAINTENANCE

- 1 The face of the disc and belt should be kept clean and free from grease or other liquids.
- 2 **IMPORTANT:** The pulley should be run through its speed range after each several hours of operation in order to lubricate all working surfaces.
- 3 **LUBRICATION:** The lubricant to be used should be a premium lithium based grease. Grease pulley after approximately 40 hours of operation.

**CAUTION: DO NOT OVER GREASE.** One or two cubic inches of grease is sufficient. Too much grease could spread to belt.

Item Number	Document Number	Title	Quantity
1	#1652-B	Alemite Grease Fitting	1
2	I8241-A	Vari-Drive Shaft	1
3	5100-I25	External Retaining Ring	1
4	I8242-A	Vari-Drive Retainer	1
5	I8243-A	Vari-Drive Cup Shield	1
6	I8252-A	Spring	2
7	I8239-B	Vari-Drive Sheave, Front	1
8	I8240-B	Vari-Drive Sheave, Rear	1
9	I/4-20 x I/4	Set Screw-Cup pt. with Thread Lock	2

I8246-A

I8351-A Key

First Used On	
Model	Serial No.
4V-18	I160
4V-24	638
4V-36	I061

<b>GROB INC.</b>		<b>GRAFTON, WIS.</b>	
Vari-Drive Pulley Assembly for 4V Band Saws			
DRN	KS	TR	CH
DATE	I-29-01	SCALE	I:2
NO. REQ'D	PATT. NO.	MATERIAL	HEAT TREATMENT
			I8246-A

## *IMPORTANT NOTICE !!*

### IDENTIFICATION OF GROB SELF SEATING SAW GUIDES

YELLOW-----1/8"x .025"    WHITE-----3/8" - 1/2"x .025"

RED----- 3/16"x .025"    BLACK-----5/8"x .032"

GREEN-----1/4" - 5/16"x .025"    BROWN-----3/4"x .032"

BLUE-----3/8" - 1/2"x .035"    ORANGE-----7/8" - 1"x .035"

AFTER SAW GUIDES HAVE BEEN SEATED, THEY WILL WEAR VERY LITTLE. IT IS IMPORTANT THAT A "SEATED GUIDE" IS CLAMPED IN ITS PREVIOUSLY "SEATED" POSITION.

FOR BETTER SERVICE AND LONGER LIFE OF SAW BLADE,  
ALWAYS CLAMP GUIDE IN SAME RELATIVE POSITION TO WORK.

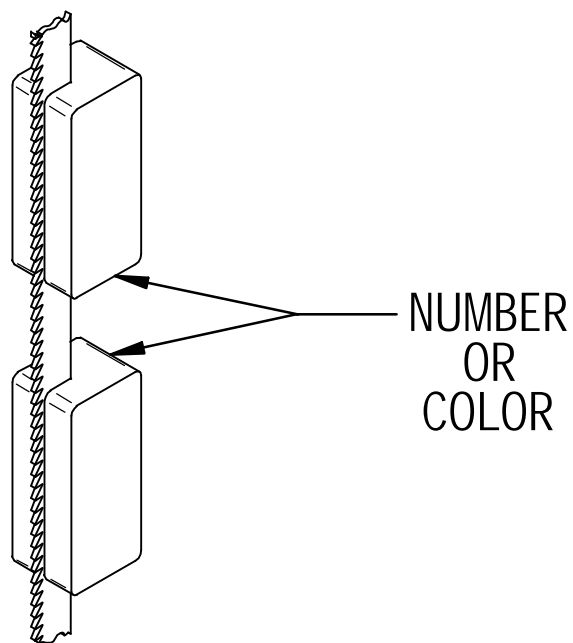



# GROB 4V-24 Parts

**GrobBandSaw.com**  
**888-550-3116**

